

MODEL AL-125 DIAGRAM SPECIFICATIONS

SPECIFICATIONS
(CENTIMETERS ARE REPRESENTED BY [])

MAX WEIGHT CAPACITY : 125 LBS [56.7 KG]
 MAX TRAVEL (EXTENSION) : 26" [66]
 MAX BOX DIMENSIONS (W X H X D) : 30" X 25.75" X 30" [76.2 X 65.4 X 76.2]
 BOX HEIGHT + LID THICKNESS CANNOT EXCEED 25.75" [65.4]
 LIFT SYSTEM HEIGHT : 20.75" [52.7]

RETRACTED VIEW

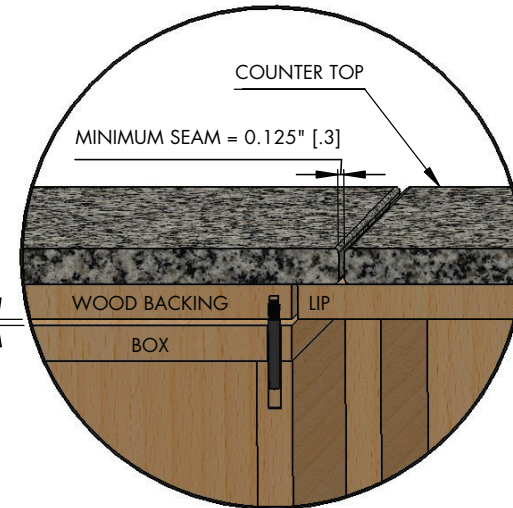

EXPLODED VIEW

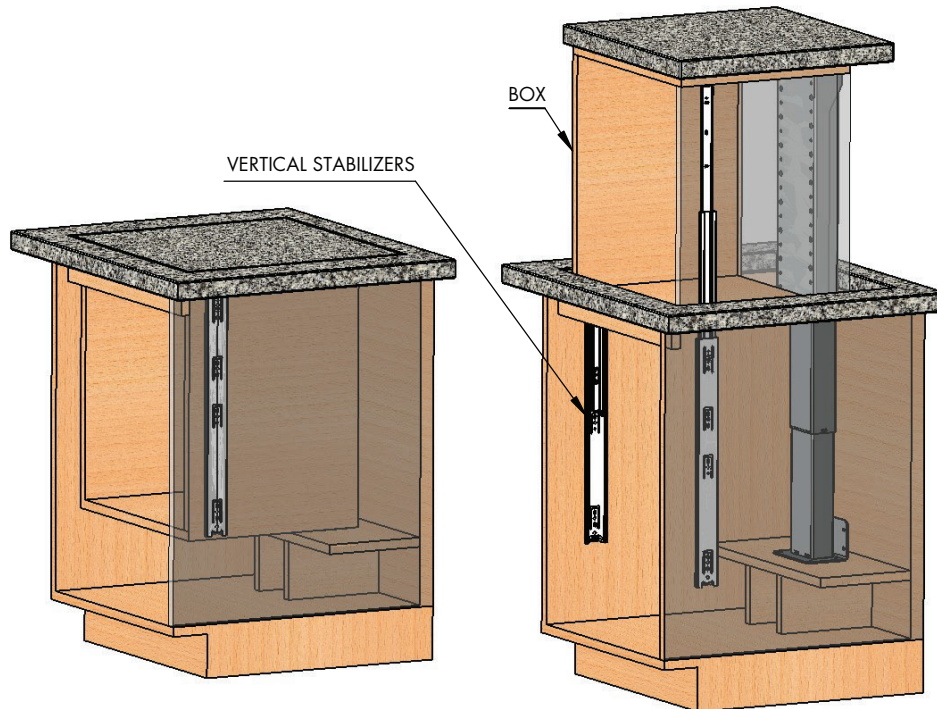
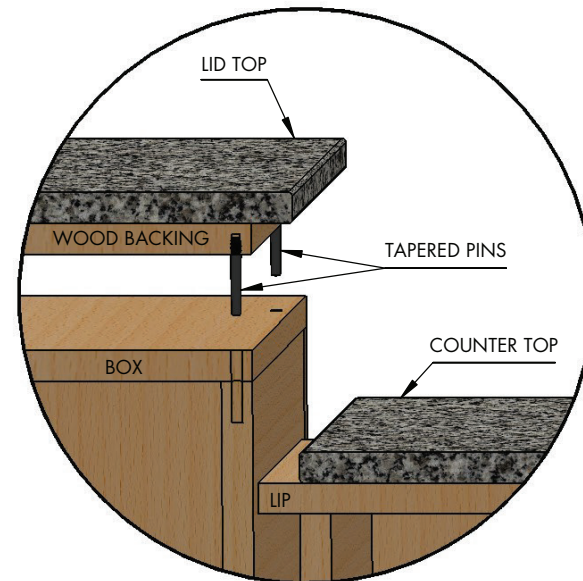

NOTES:

1. THE CABINET BOX SHOWN IN THE DIAGRAM IS FOR REFERENCE ONLY AND IS NOT PROVIDED WITH THE LIFT SYSTEM
2. VERTICAL STABILIZERS ARE REQUIRED FOR THIS INSTALLATION, TO ENSURE MINIMAL DEFLECTION AND IDEAL PERFORMANCE
3. BOX CAN BE ANY SHAPE, AS LONG AS THE MAXIMUM BOX DIMENSIONS ARE NOT EXCEEDED
4. TAPERED PINS ALLOW LID TO "FLOAT" WITH THE USE OF LIP OR LID CATCH
5. LID MUST BE REMOVABLE / "FLOATING" FOR WARRANTY, RELIABILITY AND SAFETY. COLLISION DETECTION SYSTEM IS EXTREMELY SENSITIVE

NEXUS₂₁

COPYRIGHT 2020 - ALL RIGHTS RESERVED
 UPDATED 4/15/21

MODEL AL-125 DIAGRAM MECHANISM DIMENSIONS

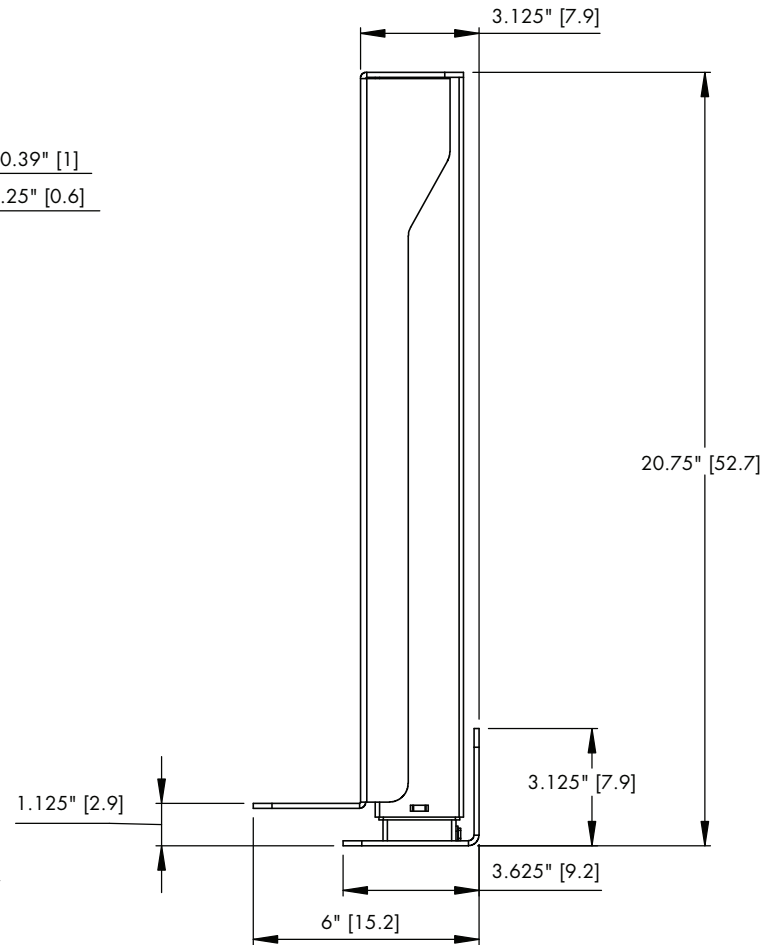
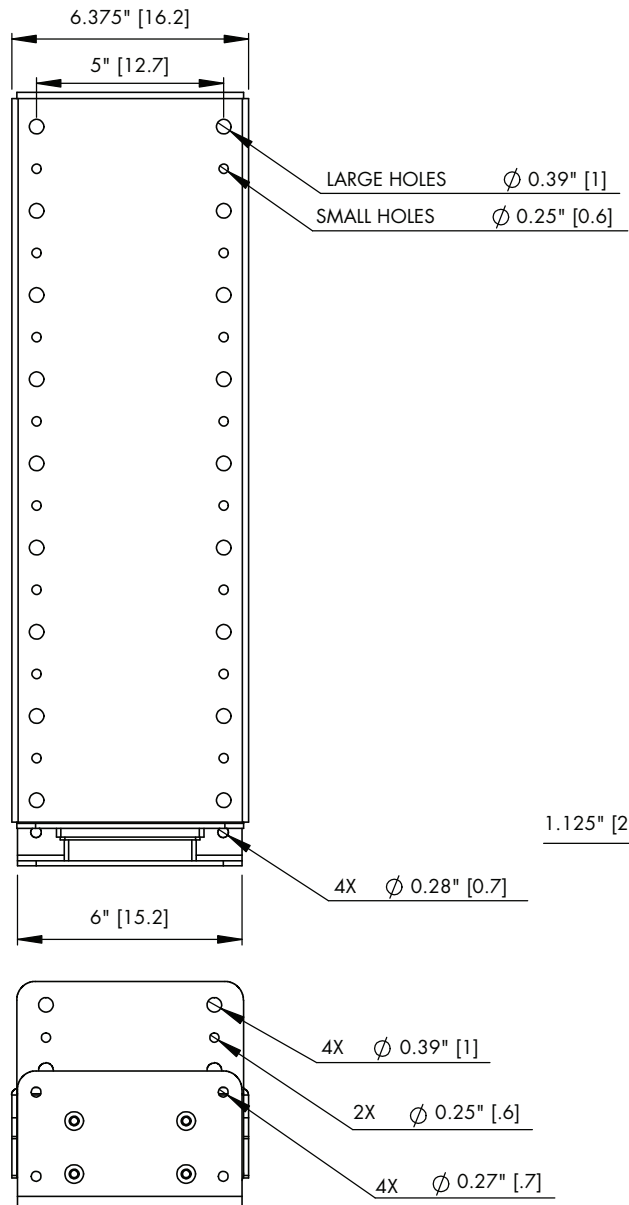

RETRACTED VIEWS

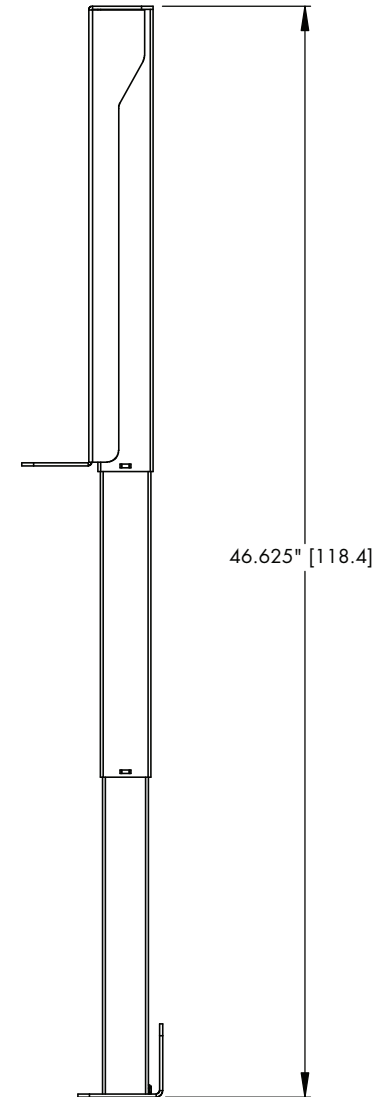

EXTENDED VIEW

NEXUS₂₁

COPYRIGHT 2020 - ALL RIGHTS RESERVED
UPDATED 4/15/21